



**OUTSIDE AIR LOUVERS**

4" OUTSIDE AIR LOUVERS WITH DRAINABLE BLADE

**MODELS: OL-4-DB-FL, OL-4-DB-CH**

**SUSTAINABLE EXTRUDED ALUMINUM**

**Dimensions are in inches**

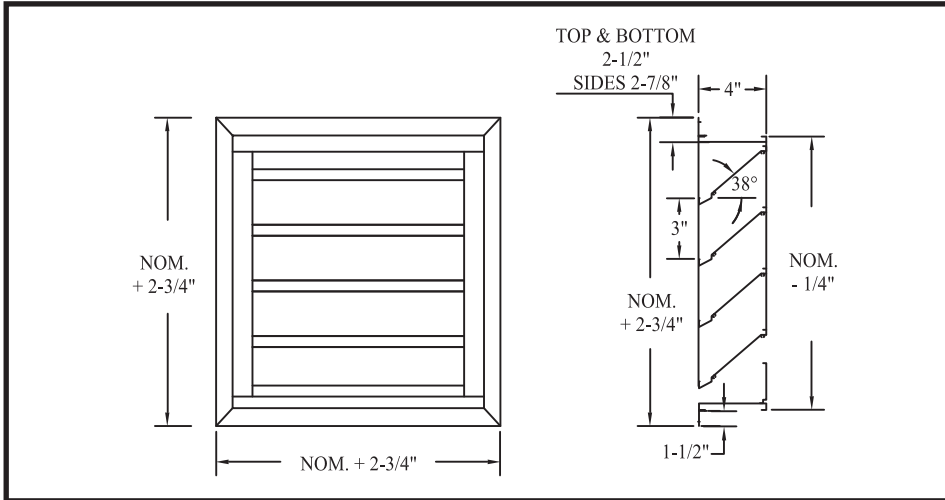

**OL-4-DB-FL**

4" Outside air louvers with drainable blades and flange frame.

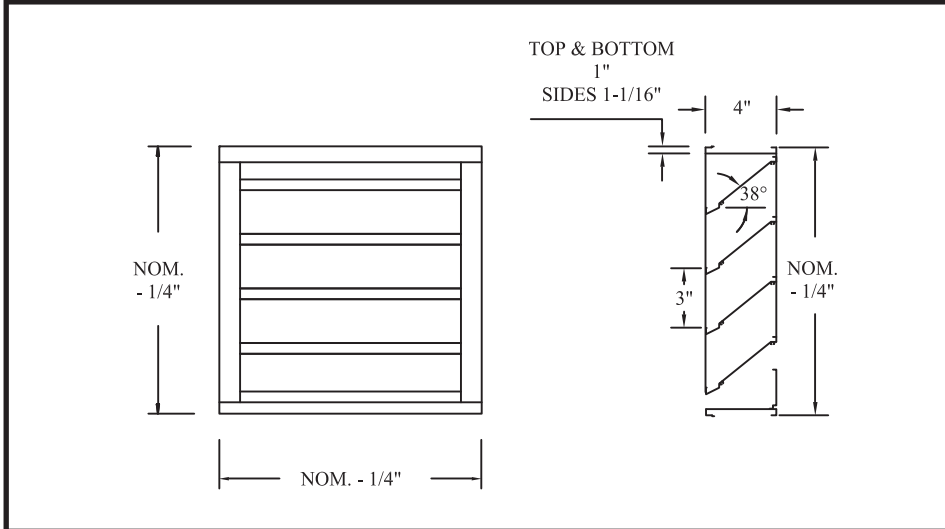

**OL-4-DB-CH**

4" Outside air louvers with drainable blades and channel frame.

**DESCRIPTION:**

1. High performance drainable blade 4" louver fabricated with mechanically joined 6063 extruded aluminum alloy. Frames are .100" with blades being .081".
2. Blades are spaced 3" on centers at an angle of 38°. The blade design allows for excellent drainage of water through the horizontal gutter to the vertical drainage channel in the jambs and mullions.
3. Maximum one-piece construction is 12' wide x 8' high. Joining mullions are furnished for larger sizes.
4. Standard finish is mill aluminum with a variety of anodized and high performance painted finishes available.

**OPTIONS:**

1. Finish
  - White
  - ANOD Clear Anodized
  - Medium Bronze
  - Black
  - Custom \_\_\_\_\_
2. Options
  - OBFL (Fire link)
  - Expanded Aluminum Bird Screen
  - Woven Fiberglass Insect Screen
  - Filter Frame
  - Opposed Blade Damper

**PROJECT:**

**ENGINEER:**

**CONTRACTOR:**

**DATE**

**SERIES**

**DRAWING NO.**